

SCREW AIR COMPRESSOR CONTROLLER

MAM6070M

MAM6070MS



USER

MANUAL

Joy Machinery (Shanghai) Co., Ltd.

Address: Building 8, No.1098, Chuansha Road, Pudong New District
Shanghai City, China

Telephone: (+21) 60382839

Fax: (+21) 60382839

Website: www.shairbuild.com

E-mail: info@shairbuild.com

VOTE OF THANKS

Thank you for your trustworthy and select of our air compressor controller !

Joy Machinery (Shanghai) Co., Ltd specializes on the manufacture and R&D of air compressor controller. We are devoted to win customer trust through our high quality products and service.

We try our best to ensure the completeness and correctness of the manual, but our company shall reserve the rights for continuous research and improvement on its products and assume no obligation for the modification and improvement on the previously delivered products. The design of products is subject to the change without notice.

Please feel free to contact our after-sale service center if you encounter any problem with our product.

You are always welcome to make suggestions and advice!

NOTICE



Please read all the operation manual before operating the set and keep this manual for further reference.



Installation of MAM-6070MS compressor controller can be performed only by professional technicians.



Installation position shall be considered carefully in order to ensure good ventilation and reduce electromagnetic interference.



Wiring shall be performed respectively according to regulations for heavy and weak current to reduce electromagnetic interference.



RC snubber must be connected to the two terminals of coil (such as AC contactor ,valve, etc),which are controlled by relay output.



Port connection shall be inspected carefully before power on.



Correct ground connection (the third ground)can help increase product capacity of resisting signal interference.



Set rated current of motor: the max current of motor/1.2.

Features:

- **Motor and fan frequency conversion.**
- **5 inch color LCD screen ,with button and touch panel.**
- **Support real time power consumption and accumulative power consumption measurement.**
- **More accurate in setting frequency to inverter through 485 communication**
- **Free to control all inverter supporting MODBUS RTU protocol.**
- **High integration, high reliability, high cost performance**

Content

1 Basic Operation	5
1.1 Button Explanation	5
1.3 Status Display and Operation	5
1.4 Running Parameter	6
1.5 User parameter	8
1.6 Factory parameter	10
1.7 Calibration parameter	11
1.8 Block Parameter	12
1.9 Hardware parameter	12
1.10 Maintenance parameter	13
1.11 Inverter Set	14
1.12 Touch Calibration	15
1.13 History Record	15
1.14 Motor VSD	15
1.15 Fan VSD	19
1.16 Operation Authorization and Password	20
2 Controller Function and Technical Parameter	20
3 Model and Specifixation	21
3.1 Model explanation	21
3.2 Power specification sheet for corresponding fan motor	21
4 Installation	22
4.1 Mechanical Installation	22
4.2 Controller installation	22
5 Alarm function	24
5.1 Air Filter Alarm	24
5.2 Oil Filter Alarm	25
5.3 O/A Separator Alarm	25
5.4 Lubricant Alarm	25
5.5 Grease Alarm	25
5.6 Discharge High Temperature Alarm	25
6 Controller Protection	25
6.1 Fan motor Protection	25
6.2 Protection of Discharge Temperature High	25
6.3 Protection of fan motor anti-reversal	25
6.4 Protection of Air Pressure High	25
6.5 Protection of Sensor Fault	26
6.6 Protection of low temperature	26
7 Trouble Shooting	26
8 Block control and network communication	26
8.1 Block Control:	26
8.2 Network Communication	27
9 Inverter Control	28
10 Schematic Diagram	31
Appendix: Output Mode Introduction:	32

1 Basic Operation

1.1 Button Explanation



Picture 1.1.1

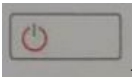

Start/Stop Button:

- When compressor is at stop status, press this button to start the compressor.
When compressor is set as master (No.1) in block status, press this button to start the compressor and activate block mode function at the same time.
- When the compressor is at running status, press this button to stop the compressor.
When compressor is set as master (No.1) in block status, press this button to stop compressor and block function as well.

1.2 Indicator explanation



Power: Indicator is alight when controller is powered on.

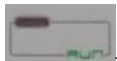

Run: Indicator is alight when motor is running.

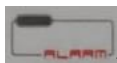

Alarm: Indicator is blinking when controller is alarming;

Indicator is alight when compressor is **alarm or fault**;

Indicator is off after error is cleared and reset.

1.3 Status Display and Operation

The display screen will show as below after power on and display “MAM-6070MS” for a while:



After 5 seconds, the menu will switch as below:

This icon means auto restart function is activated

This icon means network function is activated

This icon means remote function is activated

This icon means computer monitor function is activated

To prevent interference, it will take 0.2S to take effect ion after press start or stop icon

User can enter the below menu through clicking MENU icons on the screen.

User can enter the corresponding menu through

1.4 Running Parameter

Click “RUN PARAMETER” to check the relative data and setting below:

Menu	Preset Data	Function
------	-------------	----------

OIL FILTER	0000H	Record total running time of oil filter.
O/A SEPERATOR	0000H	Record total running time of O/A separator.
AIR FILTER	0000H	Record total running time of air filter.
LUBE	0000H	Record total running time of lubricant
GREASE	0000H	Record total running time of grease
SERIAL NO	00000000	Display serial NO.
MOTOR CRURRENT	A: 000.0A B: 000.0A C: 000.0A	Display motor current.
FAN CURRENT	A: 000.0A B: 000.0A C: 000.0A	Display fan current
MOTOR RATED SPEED	0000 RPM	Display motor actual speed based on the calculation of motor frequency read
MOTOR FREQ.	000.0 Hz	Display the output frequency of the main inverter.
MOTOR OUTPUT CURRENT:	000.0 A	Display the output current of the main inverter.
MOTOR VOLTAGE	000.0 V	Display the output voltage of the main inverter.
MOTOR OUTPUT POWER:	000.0 Kw	Display the real time output power of the main inverter
MOTOR THIS POWER CONSUMPTION	0000000. 0Kw.H	Display the accumulative this power consumption based on the main inverter real time output power
MOTOR TOTAL POWER CONSUMPTION	0000000. 0Kw.H	Display the accumulative total power consumption based on the main inverter real time output power
PRESSURE	00.00MPa	Display the current pressure.
MOTOR STATE DESCRIPTION:	0001	Display the main inverter state description, here according to the hex read by controller.
MOTOR ERROR DESCRIPTION:	0000	Display the main inverter error description, here according to the hex read by controller.
WRITE FREQUENCY:	000.0	Display output frequency send to the main inverter.
FAN SPEED	0000 RPM	Display the fan real time speed based on the fan frequency read
FAN FREQUENCY:	000.0 Hz	Display the output frequency of the fan inverter
FAN CURRENT:	000.0 A	Display the output current of the fan inverter
FAN VOLTAGE:	000.0 V	Display output voltage of the fan inverter
FAN OUTPUT POWER:	000.0 Kw	Display the real time output power based on the the fan inverter
FAN THIS POWER CONSUMPTION	0000000. 0Kw.H	Display the accumulative this power consumption based on the fan inverter real time output power
FAN TOTAL POWER CONSUMPTION:	0000000. 0Kw.H	Display the accumulative total power consumption based on the fan inverter real time output power
TEMPERATURE	0000°C	Display the element temperature
FAN STATE DESCRIPTION:	0203	Display fan inverter state description here according to the hex read by controller.

ERROR DESCRIPTION:	0000	Display motor error description of fan inverter here according to the hex read by controller.
WRITE FREQUENCY:	000.0	Display the fan frequency based on the PID calculation.
PRODUCTION DATE:	0000-00-00	Display production date.
THIS RUN TIME	0000:00:00	Record compressor this run time
THIS LOAD TIME:	0000:00:00	Record compressor this load time
CHECK 1:	00003FFF	Display check 1.
CHECK 2:	00003FFF	Display check 2.
SOFTWARE EDITION:	CK0000 M0000	Display software edition.
INPUT STATE:	5 6 7 ● ● ● 5: In accordance with No.5 digital input state; 6: In accordance with No.6 digital input state; 7: In accordance with No.7 digital input state; Red circle of input state means terminal is connected; Orange circle of input state means terminal is disconnected	
OUTPUT STATE	16 15 13 ● ● ● 16: In accordance with No.16 digital output state;; 15: In accordance with No.15 digital output state; 13: In accordance with No.13 digital output state; Red circle of input state means terminal is connected; Orange circle of input state means terminal is disconnected	

1.5 User parameter

User parameter is used to store relative data. User password is required for modification.

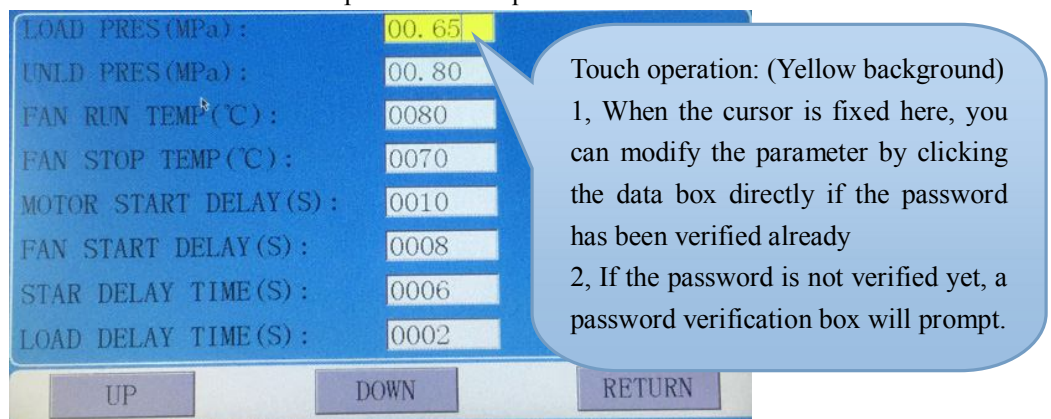

Main function is as below:

Menu	Preset Data	Function
------	-------------	----------

LOAD P (MPa)	00.65	1,In AUTO load mode, compressor will load if pressure is below this setting data 2,In STANDBY mode, compressor will start if the pressure is below this setting data.
UNLOAD P (MPa)	00.80	1,Compressor will unload automatically if air pressure is above this setting data 2.This data should be set above LOAD P, also should be set below UNLD P LIM
FAN START T (°C)	0080	Fan will start if the element T is above this set data
FAN STOP T (°C)	0070	Fan will stop if the element T is below this set data.
FAN START DELAY(S):	0008	Set the FAN START TIME. Record time when fan is activated, controller will not start overload protection during this time to avoid impulse starting current stopping the fan.
LOAD DELAY(S):	0002	Unloading in this set time after enter delta running
STOP DELAY(S):	0010	For NORMAL STOP operation, compressor will stop after it continuously unloads over this set time
RESTART DELAY(S):	0100	Machine can start only over this set time at any case(after normal stop, standby or alarm & stop)
STANDBY DELAY(S):	1200	When unloading continuously, compressor will automatically stop and enter to standby status if over this set time
SLEEP BACKLIGHT	0000	Set the backlight brightness of the controller in the case of no operation for a long time
WORK BACKLIGHT :	0007	During manual operation, the backlight brightness, the higher the data, the brighter the display(from level 1 to level 4)
COM ADD:	0001	Set the communication address in COMPUTER or NETWORK mode. This address is unique for every controller in net
MOTOR VSD P (MPa)	00.70	Set AIR P in VSD mode to keep running stable. When pressure is fluctuated around this data, controller will adjust operating frequency of inverter to control the pressure close to this data(This data is only available in MOTOR VSD or MOTOR/FAN VSD mode)
FAN VSD T (°C)	0078°C	In VSD mode, set DISC T to keep running stable. When DISC T is fluctuated around this data, controller will adjust operating frequency of fan inverter to control DISC T close to this data(This data is only available in FAN VSD or MOTOR/FAN VSD mode)
LOAD MODE:	MANUAL/AUTOMATIC	MANUAL : only when the pressure is above UNLD P, compressor will unload automatically .For any other case ,the Load/Unload function can only be executed by pressing “load/unload” key AUTOMATICAL: the load/unload function can be executed by the fluctuation of AIR P automatically

START MODE:	LOCAL/REMOTE	LOCAL: only the button on the controller can turn on and turn off the machine REMOTE: both the button on the controller and the remote control button can turn on and turn off the machine Note: When one input terminal is set as REMOTE START ENABLE, start mode is controlled by hardware status. It is remote when terminal is close, it is local when terminal is open In this case, the set here is not available
RUN MODE	MOTOR VSD/MOTOR FAN VSD	Choose the corresponding compressor run mode according to customer requirement and choose the corresponding schematic diagram for reference.
COM MODE:	COMPUTER/BLOCK/DISABLE	DISABLE: communication function is not activated. COMPUTER: compressor can communicate with computer or DCS as slave according to MODBUS-RTU. Baud rate:9600;Data format:8N1;Parity bit: even parity check BLOCK: compressors can work in a net
PRESSURE UNIT:	MPa/PSI/BAR	MPa: pressure unit displays as MPa PSI: pressure unit displays as PSI BAR: pressure unit displays as BAR
TEMPERATURE UNIT:	°C/°F	°C:temperature unit displays as °C °F:temperature unit is displays as °F
LANGUAGE:	CHINESE/ENGLISH	ENGLISH: Displays in English CHINESE: Displays in Chinese
USER PASSWORD:	****	User could modify the user password by old user password or factory password

1.6 Factory parameter

Factory parameter is used to store relative data. Factory password is required for check and modification.:

Menu	Preset Data	Function
UNLD P LIM (MPa):	00.85	This data is the maximum of UNLD P. The UNLD P in the customer parameter must be set no higher than this data.
FAULT RECORD RESET:	****	Input"8888"and press "set" button to clear all the history fault record.
ALARM LONG STOP (H) :	0000	When controller detects oil filter, air filter, O/A separator lubricant and grease running over the max time and alarm over the data set, compressor will alarm and stop
MAX RUN TIME (H) :	0000	1, When the compressor is in a stop status and the TOTAL RUN TIME is over this MAX TIME set, compressor will alarm and stop, reporting USER MISTAKE 2, Set the data to '0000', this function is not activated.
FAN RATED CURRENT (A) :	Maximum fan overload data/1.2	When the current of fan is more than 1.2 times than the set data , the unit will stop for overload feature.

ALARM DISC T (°C) :	0105	When discharge temperature reaches this set data, compressor will alarm
STOP DISC T (°C) :	0110	When the discharge temperature reaches this set data, compressor will alarm and stop
STOP PRES (MPa) :	00.90	When pressure reaches this set data ,compressor will alarm and stop
FACTORY PASSWORD 2:	****	Set a FACTORY PASSWORD which can be modified.
VSD COM OVERTIME (S) :	002.0	Record time when controller sent first data, if controller failed to receive the feedback from inverter within this set time, controller is regarded overtime and will send command again.
VSD COM INTERRUPT (S) :	0020	If controller failed to receive feedback from inverter for this set time, VSD COM is interrupted.
VSD COM RESTORE:	0015	After VSD COM is interrupted, and controller receives the correct data more than this set times, VSD COM is regarded restored.
SCHEDULED ON/OFF:	DISABLE/ ENABLE	ENABLE: SCHEDULED ON/OFF is valid DISABLE: SCHEDULED ON/OFF is invalid
FREQ SELECT:	50HZ/60HZ	Set the working power frequency of the air compressor.
TOTAL RUN TIME (H) :	000100H : 00M	Revise total run time
TOTAL LOAD TIME (H)	000100H : 00M	Revise total load time
LOW TEMP PROT (°C) :	-0050	After turn on, if the detected temperature is lower than this value, the controller will display low temperature and the compressor is not allowed to start; Two seconds after the controller turns on, if the detected temperature is lower than this value, controller makes temperature sensor fault and stop
SERIAL NO.:	12345678	The serial number from the manufacturer
PROD DATE:	2016-02-20	The production date

1.7 Calibration parameter

Calibration parameter is used to store relative data. Calibration password is required for check and modification. Main function is below.

Menu	Preset Data	Function
FAN A COEF	1.000	Input the coefficient to calibrate current.
FAN B COEF	1.000	Controller display current=sample current*coefficient. The range of coefficient: 0.800~2.000
FAN C COEF	1.000	
FAN CURR RATIO	001	Fan rated current /5
P 1 COEF	1.000	Input the coefficient to calibrate air pressure. Controller display pressure =sample pressure*coefficient. The range of coefficient:0.800-2.000
T 1 COEF	1.000	Input the coefficient when calibrate discharge temperature. Controller display temperature=sample temperature*coefficient. The range of coefficient: 0.800-2.000

T 1 ZERO	0002	Calibrate controller temperature zero. Calibrate temperature to -20°C when controller pressure sensor terminal connects the resistance in accordance with -20°C. For the calibration of temperature, it is required to calibrate T zero first and then calibrate coefficient
P1 SENSOR RANGE	01.60	Set AIR P sensor range
PHASE PROT (V)	000.9	If the Three phase voltage is detected lower than the data set here, controller will report PHASE WRONG If PHASE PROT =0 second, PHASE PROT is not activated
CLR RESET INFOR	0000	Used for manufacturer debugging

1.8 Block Parameter

Block parameter is used to store relative data. Block password is required for check and modification.

Main function is below.:

Menu	Preset Data	Function
BLOCK NUMBER	0002	Number of air compressors in block net
BLOCK LOAD P (MPa)	00.63	In BLOCK mode, one compressor will start or load when master AIR P is below this set data
BLOCK UNLOAD P (MPa)	00.78	In BLOCK mode, one compressor will stop or unload when master AIR P is above this set data
BLOCK DELAY (S)	0020	In BLOCK mode, when master sends two commands continuously, second command signal delays for this set data
TURN TIME (M)	0060	When master pressure is between BLOCK LOAD P and BLOCK UNLD P, master determines slave to work alternatively after working over this set time
BLOCK MODE	PF-PF VSD-PF VSD-VSD	PF-PF:PF compressor and PF compressor work in block mode VSD-PF: VSD compressor and PF compressor work in block mode VSD-VSD: VSD compressor and VSD compressor work in block mode

1.9 Hardware parameter

Hardware parameter is used to set the function from 5-10 terminals. Main function is below

Menu	Preset Data	Function
5 TERMINAL:	Emergency	NO FUNCTION/EMERGENCY/REMOTE ON/REMOTE OFF/REMOTE INCHING/KEEP REMOTE / LACK WATER (N.C.)/REMOTE LOAD/REMOTE START
6 TERMINAL:	MOTOR INV FAULT	ENABLE/REMOTE LOAD/UNLD /TANK HIGH T (N.C.)/ COIL HIGH T (N.C.)/ BEARING HIGH T (N.C.)/ ELEC FAULT (N.C.)/MOTOR OVLD (N.C.)/FAN OVLD (N.C.)/OIL

7 TERMINAL:	REMOTE ON-OFF	BLOCK (N.C.)/ OIL BLOCK (N.O.)/O/A BLOCK (N.C.)/O/A BLOCK (N.O.)/AIR FILTER BLOCK (N.C.)/AIR FILTER BLOCK (N.O.)/ AIR FAULT (N.C.)/DRYER FAULT (N.C.)/ MOTOR INV FAULT (N.O.)/ MOTOR INV FAULT (N.C.)/ FAN INV FAULT (N.O.)/ FAN INV FAULT (N.C.) Note: User can set different digital input function
-------------	---------------	--

1.10 Maintenance parameter

Maintenance parameter is used to store maintenance data. Maintenance password is required for check and modification. Main function is below.:

Menu	Preset Data	Function
OIL FILTER RUN TIME (H)	0000	Record total running time of oil filter. If changing new oil filter, the data should be reset by manual operation.
O/A SEPERATOR RUN TIME(H)	0000	Record total running time of O/A separator. If changing new O/A separator, the data should be reset by manual operation
AIR FILTER RUN TIME (H)	0000	Record total running time of air filter .If changing new air filter, the data should be reset by manual operation
LUBRICANT RUN TIME (H)	0000	Record total running time of lubricant. If changing new lubricant, the data should be reset by manual operation
GREASE RUN TIME (H)	0000	Record total running time of grease. If changing new grease, the data should be reset by manual operation
OIL FILTER MAX RUN TIME (H)	2000	1, Alarm prompt when total running time of oil filter is above the set data . 2,Set this data to “0000” , alarm function for oil filter running time is not activated
O/A SEPERATOR MAX RUN TIME(H)	2000	1, Alarm prompt when total running time of O/A separator is above the set data. 2,Set this data to “0000” ,alarm function for O/A separator running time is not activated
AIR FILTER MAX RUN TIME (H)	2000	1, Alarm prompt when total running time of air filter is above the set data. 2,Set this data to “0000” , alarm function for air filter running time is not activated
LUBRICANT MAX RUN TIME (H)	2000	1, Alarm prompt when total running time of lubricant is above the set data. 2, Set this data to “0000”, alarm function for lubricant running time is not activated.
GREASE MAX RUN TIME (H)	2000	1, Alarm prompt when total running time of grease is above the set data. 2,Set this data to “0” , alarm function for grease running time is not activated

1.11 Inverter Set

Inverter set is used to set inverter data. Inverter password is required for check and modification. Main function is below.(The following chart is an example of Shneider inverter ATV61、ATV71)

Menu	Preset Data	Function
INVERTER NAME:	0ATV61	Set inverter name
RUN(W) ADD1:	2135	Corresponding address 1 of inverter start command
RUN VALUE:	0001	This data is inverter start data (please refer to communication chapter in inverter manual for different inverter.)
RUN(W) ADD2:	2135	Corresponding address 2 of inverter start command
RUN VALUE:	0001	This data is inverter start data (please refer to communication chapter in inverter manual for different inverter.)
STOP(W) ADD:	2135	Corresponding address of inverter stop command
RUN VALUE:	0001	This data is inverter start data (please refer to communication chapter in inverter manual for different inverter.)
RESET(W) ADD:	2135	Corresponding address of inverter reset command
RUN VALUE:	0001	This data is inverter start data (please refer to communication chapter in inverter manual for different inverter.)
FREQ(W) ADD:	2136	Corresponding register address of inverter running frequency source
FREQ(R) =	REC*0001÷0001	The REC value is frequency value with one decimal. Use formula to transfer to corresponding value based on different inverter and send it to inverter. Example: 50HZ running frequency, REC value:500 For inverter with write frequency of 2 decimals, formula: REC**0001÷0010 For inverter with write frequency of 1 decimal, formula: REC**0001÷0001 For the inverter whose max output frequency is in corresponding with 10000,the formula :REC*0020÷0001
STATE(R) ADD:	2135	Read inverter running status address
RUN S =	RECEIVE AND 0001=0001	Check if inverter has run the formula(please refer to communication chapter in inverter manual)
COM FORM	8N1-N	Set the data format of controller and inverter communication. This set should be consistent with inverter communication format 8N1-N: 1start bit,8 data bits,1 stop bit, no parity bit 8N1-E: 1start bit,8 data bits,1 stop bit, even parity bit 8N1-O: 1start bit,8 data bits,1 stop bit, odd parity bit 8N2-N: 1start bit,8 data bits,2 stop bit, no parity bit Note: Communicate with inverter, the baud rate is fixed:9600
FREQ(R) ADD	0C82	Read inverter frequency address(refer to inverter manual)

FREQ(R) =	REC*0001÷0001	Calculate inverter frequency formula. Controller will transfer the frequency to one decimal.
VOLT(R) ADD	0C88	Read inverter voltage address
VOLT(R) =	REC*0001÷0001	Calculate inverter voltage formula. Controller will transfer the voltage to one decimal
CURR(R) ADD	0C84	Read inverter current address
CURR(R) =	REC*0001÷0001	Calculate inverter current formula. Controller will transfer the current to one decimal
POWE(R) ADD	0C8B	Read inverter power address
POWE=	REC*1*001 ÷ 0001	Calculate inverter power
ERR ADD	8000	Read inverter error address
ERR S =	R AND 0000≠0000	Inverter reports error formula or not
EMERGENCY ADD	2135	Corresponding add of inverter emergency stop command
RUN VALUE	0001	This data is inverter start data (please refer to communication chapter in inverter manual for different inverter.)

1.12 Touch Calibration

Touch calibration is used to adjust touch accuracy. Touch calibration password is required for adjustment. After entering touch calibration menu, use fingertip or other tool with sharp head to click the "+" icon that appears on the screen, Press "FINISH" button to restart and save the modification ; If user wants to calibrate again, press "CALBR" button to re-operate..

1.13 History Record

Record history fault for user to find causes and solutions.100 items are allowed to record.

1.14 Motor VSD

Motor VSD is used to set Motor VSD data. Motor VSD password is required for check and modification. Main function is below:

Menu	Preset Data	Function
MOTOR VSD P (MPa)	00.70	Set AIR P in VSD mode to keep running stable. When pressure is fluctuated around this data, controller will adjust operating frequency of inverter to control the pressure close to this data(This data is only available in MOTOR VSD or MOTOR/FAN VSD mode)
MOTOR START FREQ (HZ)	060.0	After the controller sends a start command to the inverter, it sends the frequency value set here to the inverter. Control motor speed need to set frequency here. Avoid running at low frequency when the air compressor is just starting up.
MOTOR RATED POWER (KW)	022.0	Set MOTOR RATED POWER in order to calculate actual power in VSD mode(This data is only available in MOTOR VSD or MOTOR/FAN VSD mode)

MOTOR RATED SPEED (RPM)	1500	Set MOTOR RATED SPEED at 50HZ in order to calculate the actual speed in VSD mode (This data is only available in MOTOR VSD or MOTOR/FAN VSD mode)
MOTOR ACC TIME (S)	0020	Use to calculate how much HZ frequency is increased per second by the inverter when controlling the acceleration operation of the inverter. For precisely control, the value here must be equal to the inverter acceleration time.
MOTOR DEC TIME (S)	0015	Use to calculate how much HZ frequency is decreased per second by the inverter when controlling the deceleration For precisely control, the value here must be equal to the inverter deceleration time.
MOTOR VSD POWER COEF	0.900	Use to calculate total power consumption when motor VSD runs.
LOW FREQ STOP DELAY (S)	0000	When motor run time under min frequency reach the value set here, stop running automatically and display LOW FREQ STOP. After pressure is lower than the loading pressure, start automatically. When it set to 0, the function is invalid.
MOTOR PROP GAIN	0010	Track speed of PID TARGET P , the bigger the data, the faster the track; the smaller the data, the slower the track
MOTOR INT GAIN	0012	Track the speed of PID TARGET P and STEADY STATE ERROR, the bigger the data ,the faster the track and smaller the STEADY-STATE ERRORS; the smaller the data ,the slower the track and bigger the STEADY-STATE ERRORS
MOTOR DIFF GAIN	0000	Track the hysteresis system(such as temperature) ,it is not used very often and normally set as “0000”
MOTOR MAX FREQ (HZ)	180.0HZ	The maximum operating frequency in loading status
MOTOR MIN FREQ (HZ)	040.0HZ	In the process of adjustment, The minimum operating frequency when pressure is over the LOAD P pressure and not reach the UNLD P
MOTOR UNLD FREQ (HZ)	025.0HZ	Permitted operating frequency in UNLD MODE
MOTOR INVERTER ADD	001	Set the MOTOR VSD ADD and keep it consistent with VSD COM ADD
SPEED ADJUST COEF	01.00	Use for constant pressure control. Range: 0~1.0 The larger this value is, the more significant the down-clocking effect is at a constant pressure point.
MOTOR INVERTER MODEL	ATV61	Controller can prestore at most 10 different inverter communication address (Inverter should support MODBUS RTU protocol for communication)

MOTOR STOP MODE	SLOW/FREE	<p>1、 INVERTER START MODE to COM ON-OFF: SLOW: When controller receives stop command, INLET VALVE terminals will open. Controller sends stop command to inverter to slow stop inverter FREE: When controller receives stop command, INLET VALVE terminals will open. Controller sends write frequency through RS485. Controller frequency will decrease and send stop command to inverter 1S before stop delay finished.</p> <p>2、 INVERTER START MODE to TERMINAL ON-OFF: SLOW: When compressor receives stop command, INLET VALVE terminals will open and MOTOR INVERTER RUN terminal will open. The compressor will stop according to STOP DELAY set. FREE: When compressor receives stop command, Inlet valve will open. MOTOR INVERTER RUN terminal will keep closed to control inverter frequency decreasing and it will open until 1 S before STOP DELAY finishes</p>
INVERTER START MODE	COM ON-OFF/ TERMINAL ON-OFF	<p>COM ON-OFF : Start or stop inverter through RS485 TERMINAL ON-OFF: Start or stop inverter through digital input Note: 1: Controller set should be accordance with INVERTER START MODE</p>
INVERTER START NO.	06	Maximum allowable time Controller sends start command to inverter with no response.
INVERTER STOP NO.	06	Maximum allowable time Controller sends stop command to inverter with no response.
VSD MOTOR POWER CONSUMPTION Kw.H	0000000.0	Set the accumulative motor VSD running power consumption.
MOTOR INVERTER DELAY(S)	001.0	Press start button, motor sends start command to inverter after this set time.
DISCH AIR MODE	ENABLE/DISABLE	is used to enable and disable the air supply mode function. See the appendix for related introduction.
CONSTANT POWER PRESSURE 1(MPa)	0.60	In constant power running mode, when pressure is above the data set here, Max output frequency is set as CONSTANT POWER FREQUENCY1
CONSTANT POWER PRESSURE 2(MPa)	0.70	In constant power running mode, when pressure is above the data set here, Max output frequency is set as CONSTANT POWER FREQUENCY2

CONSTANT POWER PRESSURE 3(MPa)	0.80	In constant power running mode, when pressure is above the data set here, Max output frequency is set as CONSTANT POWER FREQUENCY3
CONSTANT POWER PRESSURE 4(MPa)	0.90	In constant power running mode, when pressure is above the data set here, Max output frequency is set as CONSTANT POWER FREQUENCY4
CONSTANT POWER PRESSURE 5(MPa)	1.00	In constant power running mode, when pressure is above the data set here, Max output frequency is set as CONSTANT POWER FREQUENCY5
CONSTANT POWER PRESSURE 6(MPa)	1.10	In constant power running mode, when pressure is above the data set here, Max output frequency is set as CONSTANT POWER FREQUENCY6
CONSTANT POWER PRESSURE 7 (MPa)	1.20	In constant power running mode,when pressure is above the data set here, Max output frequency is set as CONSTANT POWER FREQUENCY7
CONSTANT POWER FREQUENCY 1(HZ)	180.0	See Note1:
CONSTANT POWER PRESSURE 1(MPa)	0.60	In constant power running mode, when pressure is above the data set here, Max output frequency is set as CONSTANT POWER FREQUENCY1
CONSTANT POWER PRESSURE 2(MPa)	0.70	In constant power running mode, when pressure is above the data set here, Max output frequency is set as CONSTANT POWER FREQUENCY2
CONSTANT POWER PRESSURE 3(MPa)	0.80	In constant power running mode, when pressure is above the data set here, Max output frequency is set as CONSTANT POWER FREQUENCY3
CONSTANT POWER PRESSURE 4(MPa)	0.90	In constant power running mode, when pressure is above the data set here, Max output frequency is set as CONSTANT POWER FREQUENCY4
CONSTANT POWER PRESSURE 5(MPa)	1.00	In constant power running mode, when pressure is above the data set here, Max output frequency is set as CONSTANT POWER FREQUENCY5
CONSTANT POWER PRESSURE 6(MPa)	1.10	In constant power running mode, when pressure is above the data set here, Max output frequency is set as CONSTANT POWER FREQUENCY6

Note 1: In constant power running mode

CONSTANT POWER PRESSURE 1<= CONSTANT POWER PRESSURE 2<= CONSTANT POWER PRESSURE 3<= CONSTANT POWER PRESSURE 4<= CONSTANT POWER PRESSURE 5<= CONSTANT POWER PRESSURE 6<= CONSTANT POWER PRESSURE 7

Note 2: CONSTANT POWER FREQUENCY 1>= CONSTANT POWER FREQUENCY 2>= CONSTANT POWER FREQUENCY3>= CONSTANT POWER FREQUENCY 4>= CONSTANT POWER FREQUENCY 5>= CONSTANT POWER FREQUENCY 6>= CONSTANT POWER FREQUENCY 7

Note 3: Suppose M>N, When CONSTANT POWER PRESSURE N set to 00.00, CONSTANT POWER PRESSURE M and CONSTANT POWER FREQUENCY M, the set is invalid.

Note 4: When constant power function is not required,set CONSTANT POWER PRESSURE to 00.00MPa

1.15 Fan VSD

Fan VSD is used to set Fan VSD data. Fan VSD password is required for check and modification. Main function is below.

Menu	Preset Data	Function
FAN VSD T (°C)	0078°C	In VSD mode, set DISC T to keep running stable. When DISC T is fluctuated around this data, controller will adjust operating frequency of fan inverter to control DISC T close to this data(This data is only available in FAN VSD or MOTOR/FAN VSD mode)
MAX VSD T (°C)	0085°C	When DISC T is above or equal to this data, control fan inverter output frequency to FAN MAX FREQ(This data is only available in FAN VSD or MOTOR/FAN VSD mode)
FAN UP SPEED	1000	Restrict PID calculations in case the frequency increasing too fast which cause fan speeding up too fast
FAN DN SPEED	1000	Restrict PID calculations in case the frequency decreasing too fast which cause fan slowing down too fast
FAN RATED POWER	001.5KW	Set FAN RATED POWER to calculate the actual fan power in FAN VSD mode(This data is only available in FAN VSD or MOTOR/FAN VSD mode)
FAN RATED SPEED	1500RPM	Set the corresponding fan speed in 50HZ to calculate actual fan speed in FAN VSD mode((This data is only available in FAN VSD or MOTOR/FAN VSD mode)
VSD FAN START T (°C)	0070°C	VSD fan will start if DISC T is above this set data(This data is only available in FAN VSD or MOTOR/FAN VSD mode)
VSD FAN STOP T (°C)	0065°C	VSD fan will stop if DISC T is below this set data(This data is only available in FAN VSD or MOTOR/FAN VSD mode)
FAN PROP GAIN	0100	Track speed of PID TARGET T , the bigger the data, the faster the track and the less stable the data; the smaller the data the slower the track and the slower the adjustment
FAN INT GAIN	0020	Track the speed of PID TARGET T and steady state error, the bigger the data ,the faster the track and smaller the steady-state errors; the smaller the data ,the slower the track and bigger the steady-state errors
FAN DIFF GAIN	0000	Normally set as“0000”, this function is not activated
FAN MAX FREQ (HZ)	050.0HZ	In the process of adjustment, The maximum operating frequency when temperature is over the VSD work temperature
FAN MIN FREQ (HZ)	010.0HZ	In the process of adjustment, The minimum operating frequency when temperature is below the VSD work temperature
VSD FAN POWER COEF	0.900	Coefficient to calculate VSD fan power
FAN INVERTER ADD	002	Set the FAN VSD ADD and keep it consistent with VSD COM ADD
FAN PID CYCLE (S)	001.5S	Set the PID calculation interval time to adjust fan speed.
FAN INVERTER MODEL	ATV31	Choose inverter protocol

FAN INVERTER START MODE	COM/ TERMIN AL	Set fan inverter start mode
VSD FAN ELEC (Kw.H)	000000.00	VSD fan power consumption

1.16 Operation Authorization and Password

Controller provides multiple passwords and access management. According to different levels of passwords, controller provides different levels of operating authorization, details as following:

1.16.1 CUSTOMER PASSWORD: factory set

Permissions: Allows to modify all CUSTOMER PRAMETER.

1.16.2 FACTORY PASSWORD: fixed

Permissions: Allows to modify all CUSTOMER PRAMETER.

Permissions: Allows to modify BASIC PARAMETER, MOTOR VSD PARAMETER, FAN VSD PARAMETER in FACTORY PARAMETER

1.16.3 CALIBRATE PASSWORD: fixed

Permissions: Allows to modify all CALIBRATE PARAMETER

1.16.4 BLOCK PASSWORD

Permissions: Allows to modify all BLOCK PARAMETER

1.16.5 HARDWARE CONFIG PASSWORD: fixed

Permissions: Allows to modify all HARDWARE CONFIG

1.16.6 MAINTENANCE PARAMETER PASSWORD

Permissions: Allows to modify all MAINTENANCE PARAMETER.

1.16.7 INVERTER SET PASSWORD

Permissions: Allows to modify all INVERTER SET

1.16.8 TOUCH CALIBRATION PASSWORD

Permissions: Allows to modify TOUCH ACCURACY

1.16.9 MOTOR VSD PASSWORD: fixed

Permissions: Allows to modify all MOTOR VSD PARAMETER

1.16.10 FAN VSD PASSWORD: fixed

Permissions: Allows to modify all FAN VSD PARAMETER

2 Controller Function and Technical Parameter

2.1 Working temperature: -20°C~+60°C; Humidity: ≤98%;

2.2 Digital input& output:3 points of digital input (function optional), 3 points of digital relay output

2.3 Analog input& output: 1 points of Pt100 temperature input. 1 point 4-20mA pressure input, 1 groups of three phases current input (CT provided).

2.4 Input voltage of phases: 380V/ 220V.

2.5 Controller operation power supply: AC24-28V,15VA

2.6 Measurement:

2.6.1 DISC T:-50~350°C; Accuracy: ±1°C.

2.6.2 Running time: 0~999999H.

2.6.3 Pressure: 0~1.60MPa; Accuracy: 0.01Mpa.The highest pressure range: 10.00MPa.

2.7 Phase anti-reversal protection: After the controller is powered on, the phase sequence is detected once.

- 2.8 Temperature protection: when actual temperature measured is higher than temperature set; response time \leq 2s;
- 2.9 Contact capacity of output relay: 250V,5A; Contact endurance: 500000 times;
- 2.10 Current error is less than 1.0%;
- 2.11 points of RS485communication port. 1 point is for block mode or computer communication;
The other point is for inverter communication like reading inverter run parameter, controlling inverter on-off or adjusting inverter frequency;
- 2.12 Remote control compressor: When set as REMOTE, user can remotely control the compressor.

3 Model and Specifixation

3.1 Model explanation

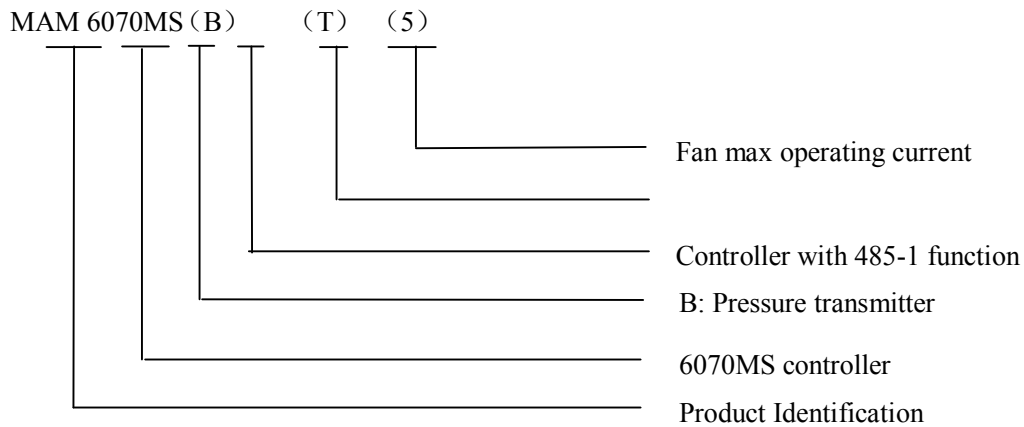

3.2 Power specification sheet for corresponding fan motor.

parameter Specificationn	Fan current range (A)	Corresponding Fan motor power (KW)	Description
MAM6070MS (5)	0.5~5	2.75KW below	Fan has three levels of current, such as 0.2-2.5A, 1-5A and 4-10A, determined-by current of motor
MAM6070MS (10)	4~10	2.2-5.5KW	
MAM6070MS (25)	8-25	4.5-13.9KW	

Table 3.2.1 Power specification sheet for corresponding fan motor

4 Installation

4.1 Mechanical Installation

The CT shall be installed at a place where the current of fan cable can be measured, thus controller can be set according to instructions on fan motor nameplate, and the detailed dimension is shown as below:

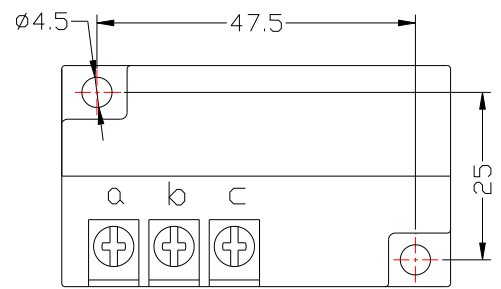
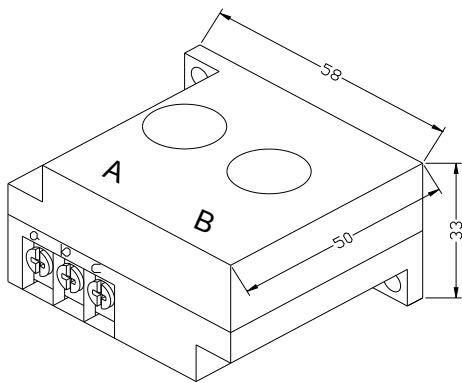

Picture 4.1.1、Structural dimension of CT2 (φ 10hole)

Picture 4. 1.2、Installation dimension of CT2

4.2 Controller installation

When install the controller, room should be left around controller for wiring. The specific dimension is shown as below:

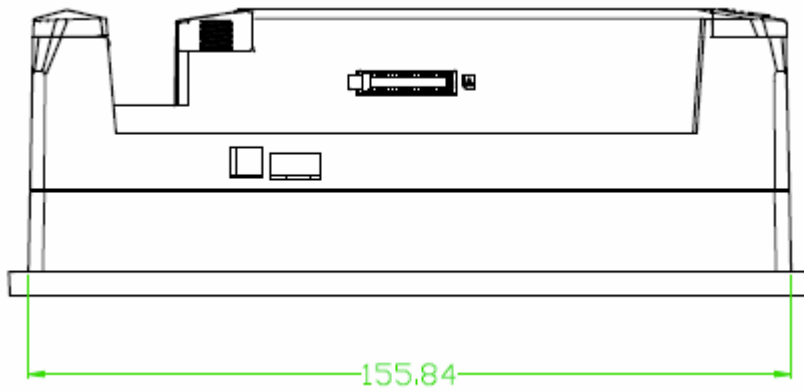
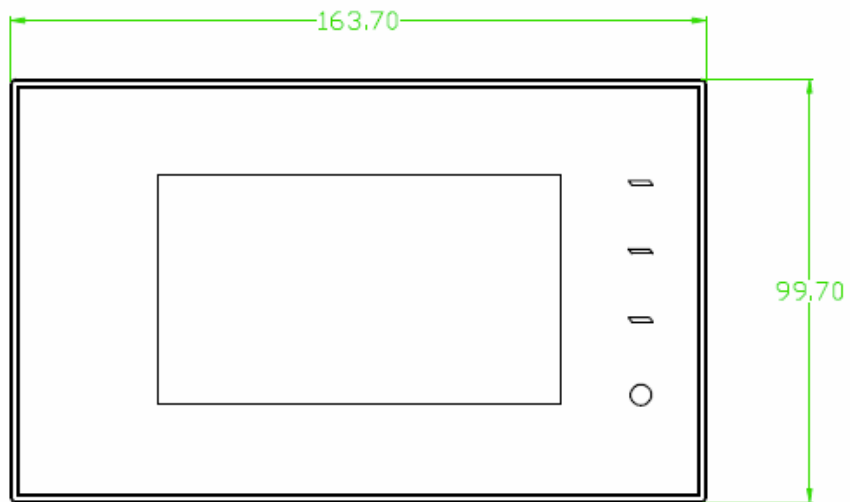
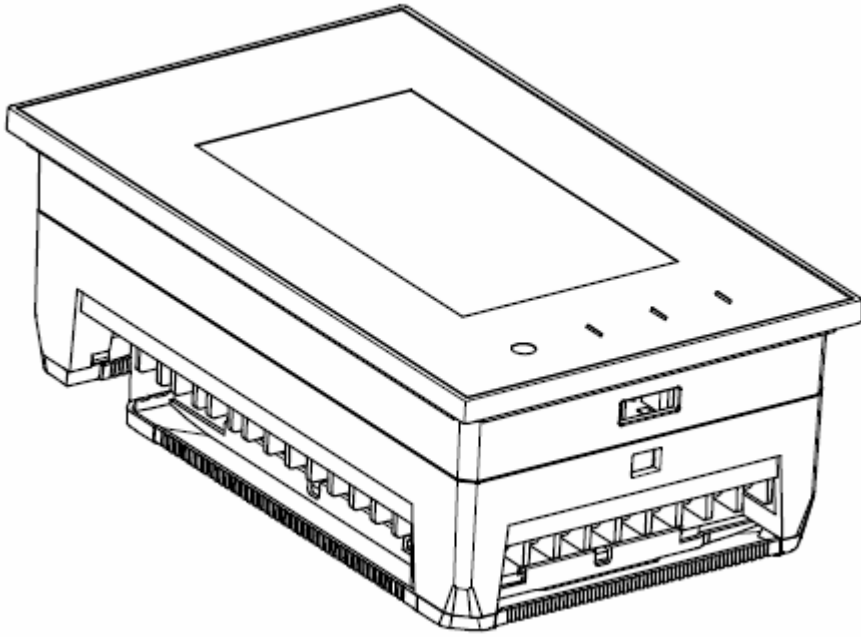

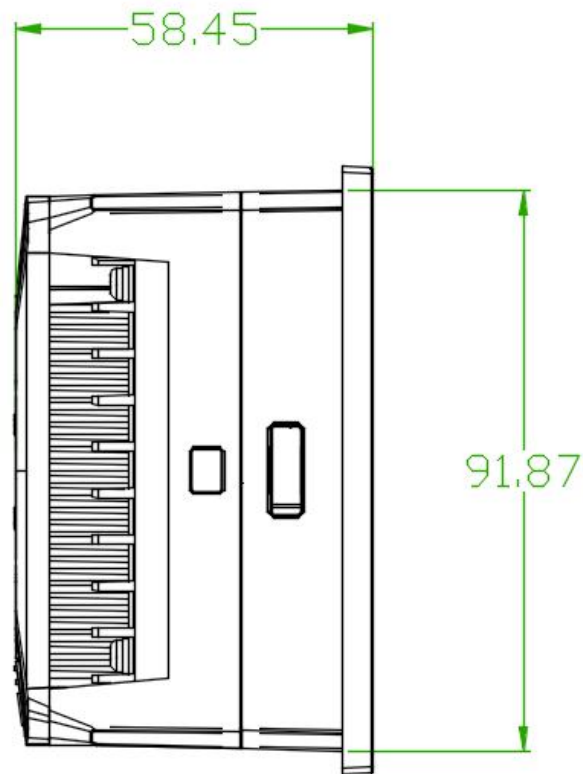

4. 2.1 Controller structure dimension

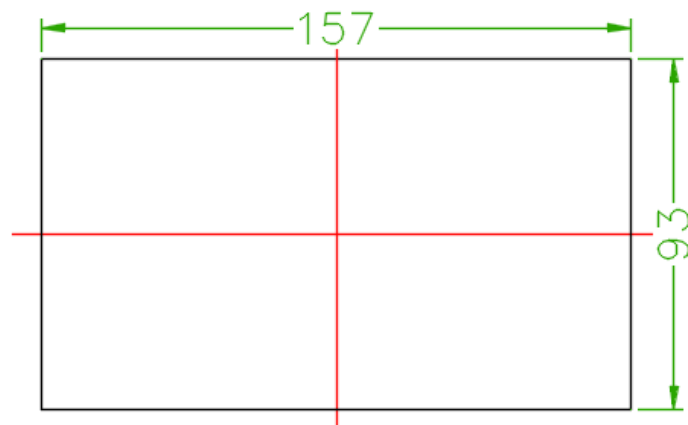

Picture 4.2.3 Hole size

Note: Though rear cabinet is 190.93mm,the hole size should be at least 206mm.After connect the cable in the rear cabinet, there will be about 10-15mm more space requested. You can save the step of dispatch cable when install controller.

5 Alarm function

5.1 Air Filter Alarm

- ①. Air filter block check. (In HARDWARE CONFIG , there is air check function set in digital input terminal)
The monitor displays AIR BLOCK by checking pressure differential switch action.

②. Air filter running time alarm

The text displays AIR TIME END when running time of the air filter is exhausted.

5.2 Oil Filter Alarm

①. Oil filter block check. (In HARDWARE CONFIG, there is oil check function set in digital input terminal)

The monitor displays OIL BLOCK by checking pressure differential switch action.

②. Oil filter running time alarm

The text displays OIL TIME END when running time of the oil filter is exhausted.

5.3 O/A Separator Alarm

①. O/A separator block check. (In HARDWARE CONFIG, there is O/A check function set in digital input terminal)

The monitor displays O/A BLOCK by checking pressure differential switch action.

②. O/A filter running time alarm

The text displays O/A TIME END when running time of the oil filter is exhausted.

5.4 Lubricant Alarm

The text displays LUBE TIME END when running time of the lubricant is exhausted.

5.5 Grease Alarm

The text displays GREASE TIME END when running time of the grease is exhausted.

5.6 Discharge High Temperature Alarm

The text displays DISC T HIGH when DISC T is higher than ALARM DISC T set in FACTORY PARAMETER.

6 Controller Protection

6.1 Fan motor Protection

When the operation mode is set as "MOTOR VSD", The controller can perform overload protection for power frequency fan.

6.2 Protection of Discharge Temperature High

When DISC T is above the STOP DISC T, the controller will alarm and stop the machine. THIS FAULT displays DISC T HIGH

6.3 Protection of fan motor anti-reversal

After the controller is powered on, the phase sequence is detected once. When a phase sequence error is detected, The controller will report "phase error " and prohibit start compressor.

6.4 Protection of Air Pressure High

When the AIR P is above the MAX LIM P, the controller will alarm and stop the machine. THIS FAULT displays HIGH P.

6.5 Protection of Sensor Fault

When pressure sensor or temperature sensor is disconnected, the controller will alarm and stop the machine. THIS FAULT displays **SENSOR FAULT.

6.6 Protection of low temperature

After the controller is powered on, if the air temperature is lower than the set value, it is forbidden to start up, and "low temperature" is displayed;

Two minutes after starting the compressor, when the air temperature is lower than the set value, it will report "low temperature" fault and stop compressor.

7 Trouble Shooting

Failure	Reason	Solution
High discharge temperature	Bad vent condition, Oil shortage etc.	Check the vent condition and lubricant amount etc.
Temperature Sensor Failure	Cable broken or PT100 failure	Check the wiring and PT100
High Pressure	Pressure too high or the pressure sensor failure	Check the pressure and the pressure sensor
Pressure Sensor Failure	Cable broken, Sensor failure or the cables connect reversely	Check the wiring and pressure transmitter
Fan overload	Voltage too low, tubes block, bearing wear off or other mechanical failure or wrong set data etc.	Check the set data, voltage, bearings, tubes and other mechanical system.
Wrong Phase Sequence	Phase sequence reversal or open phase	Check the wiring
Inverter fault I0	The controller detects that the inverter fault output terminal is disconnected	Check whether the inverter reports a fault; check whether the fault output terminal of the inverter is disconnected.
Inverter Fault	Wrong set of relatively parameter of controller and inverter;	Check the set data; Check the cable; Check whether the inverter reports a fault;

8 Block control and network communication

8.1 Block Control:

MAM6070MS controller can work in block mode with MAM series compressor (with communication function).16 pieces compressors can work together in a net at most. Block mode can be set as VSD

-VSD,PF-PF or VSD- PF .The cable connection for block mode control is as below...1,2 terminals (RS485 terminal) are used for block mode.

In BLOCK PARAMETER SET menu, set as VSD-VSD or PF-PF, master chooses compressor to work according to the TOTAL RUN TIME. Compressor with shorter running time is chosen to start and compressor with longer running time is chosen to stop with priority.

In BLOCK PARAMETER SET menu,, set as VSD-PF, master works first, other compressors work according to the TOTAL RUN TIME. Compressor with shorter running time is chosen to start and compressor with longer running time is chosen to stop with priority.

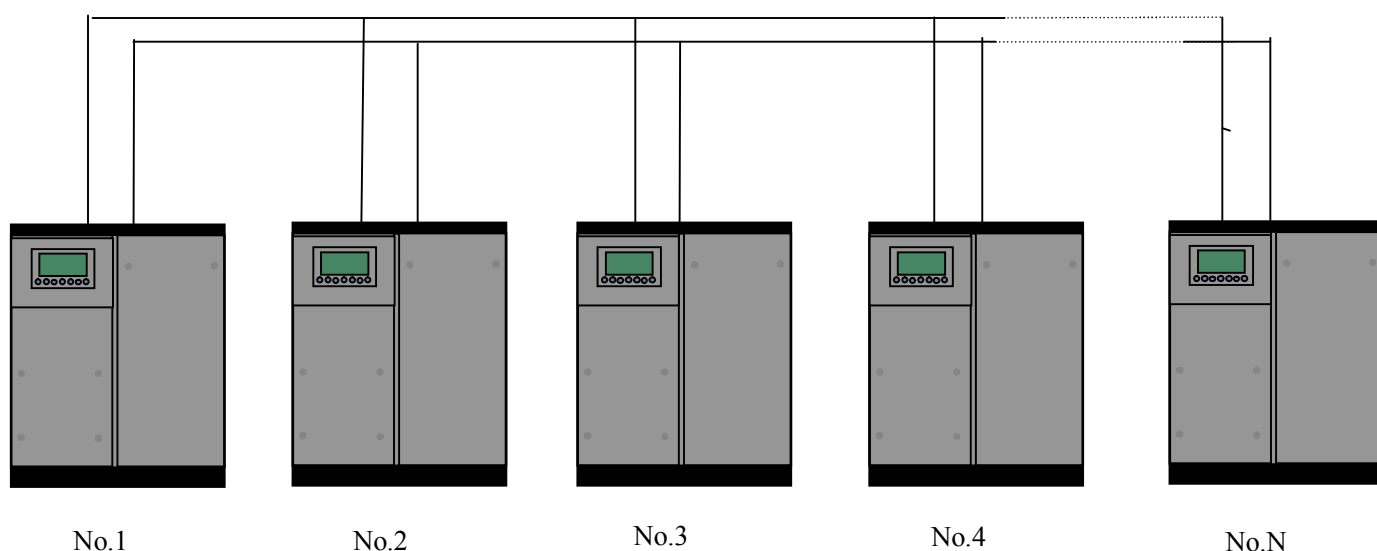

Pitcure8.1.1.1

Compressor with COM ADD 0001 is master, others are slave. Any one MAM series compressor can be set as master or slave.

8.1.1 Block Control Set:

8.1.2.1 Set as Master:

Set **the** COM ADD in USER PARAMTER to 001

According to user requirement, set COM MODE, BLOCK NUMBER, TURN TIME, BLOCK LOAD P, BLOCK UNLD P, BLOCK DELAY , BLOCK MODE .After set, controller needs to be powered off and restart to save setting.

8.1.2.2 Set as Slave:

When MAM6070MS controller serves as slave, it is only necessary to set COM MODE as BLOCK, COM ADD can be set from 2-16 in sequence according to the quantity of compressors, .BLOCK STATUS set as SLAVE.

8.1.2 Start, Stop Block mode:

Make sure block cables connect correctly, also the parameter of compressor in block mode is set correctly. Activate master, master controls the compressor in net automatically according to the AIR P detected. When manually stop the master, block control stops at the same time, thus, master will no longer send command to compressors in net.

8.2 Network Communication

MAM6070MS controller supports MODBUS RTU protocol and can serve as slave when connects with other equipment .It is supports 03、06、16 MODBUS command. Communication baud rate: 9600BPS, 1 start bit, 8

data bits, 1 stop bits and even parity. For MODBUS register address, please see MODBUS communication manual.

9 Inverter Control

485 communication control

There is one spare port for RS485 to communicate with inverter. User can start or stop controller through RS485, it transfers the output frequency based on PID calculation to inverter through 485 port. This is how to adjust inverter output frequency and realize constant pressure and temperature. The baud rate is fixed as 9600BPS when RS485 control inverter. Different inverter data format can be set in INVERTER SET in FACTORY PARAMETER. MOTOR INVERTER is suggested to be set as 0001, FAN INVERTER is suggested to be set as 0002.

In order to be compatible with different inverter, set the item such as CURR(R) ADD, VOLT(R) ADD, FREQ(R) ADD, POWE(R) ADD, RUN (W) ADD, ERR STATE(R) ADD, FREQ(W), RESET(W) ADD. For different inverter, amplification of current, voltage, frequency, power is different. Write a formula to every parameter to transfer current, voltage, frequency, power of inverter to one digit data.

Relative parameter introduction is as below, please take the Schneider 67,71 inverter as example.

Item	Data Set	Explanation
INVERTER NAME:	0ATV61	Set inverter name
RUN(W) ADD1:	2135	Corresponding address 1 of inverter start command
RUN VALUE:	0001	This data is inverter start data (please refer to communication chapter in inverter manual for different inverter.)
RUN(W) ADD2:	2135	Corresponding address 2 of inverter start command
RUN VALUE:	0001	This data is inverter start data (please refer to communication chapter in inverter manual for different inverter.)
STOP(W) ADD:	2135	Corresponding address of inverter stop command
RUN VALUE:	0001	This data is inverter start data (please refer to communication chapter in inverter manual for different inverter.)
RESET(W) ADD:	2135	Corresponding address of inverter reset command
RUN VALUE:	0001	This data is inverter start data (please refer to communication chapter in inverter manual for different inverter.)
FREQ(W) ADD:	2136	Corresponding register address of inverter running frequency source

FREQ(R) =	REC*0001÷0001	The REC value is frequency value with one decimal. Use formula to transfer to corresponding value based on different inverter and send it to inverter. Example: 50HZ running frequency, REC value:500 For inverter with write frequency of 2 decimals, formula: REC**0001÷0010 For inverter with write frequency of 1 decimal, formula: REC**0001÷0001 For the inverter whose max output frequency is in corresponding with 10000,the formula :REC*0020÷0001
STATE(R) ADD:	2135	Read inverter running status address
RUN S =	R AND 0001=0001	Check if inverter has run the formula(please refer to communication chapter in inverter manual)
COM FORM	8N1-N	Set the data format of controller and inverter communication. This set should be consistent with inverter communication format 8N1-N: 1start bit,8 data bits,1 stop bit, no parity bit 8N1-E: 1start bit,8 data bits,1 stop bit, even parity bit 8N1-O: 1start bit,8 data bits,1 stop bit, odd parity bit 8N2-N: 1start bit,8 data bits,2 stop bit, no parity bit Note: Communicate with inverter, the baud rate is fixed:9600
FREQ(R) ADD	0C82	Read inverter frequency address(refer to inverter manual)
FREQ(R) =	REC*0001÷0001	Calculate inverter frequency formula. Controller will transfer the frequency to one decimal.
VOLT(R) ADD	0C88	Read inverter voltage address
VOLT(R) =	REC*0001÷0001	Calculate inverter voltage formula. Controller will transfer the voltage to one decimal
CURR(R) ADD	0C84	Read inverter current address
CURR(R) =	REC*0001÷0001	Calculate inverter current formula. Controller will transfer the current to one decimal
POWE(R) ADD	0C8B	Read inverter power address
POWE=	REC*1*001 ÷ 0001	Calculate inverter power
ERR ADD	8000	Read inverter error address
ERR S =	R AND 0000≠0000	Inverter reports error formula or not
EMERGENCY ADD	2135	Corresponding add of inverter emergency stop command
RUN VALUE	0001	This data is inverter free stop data (please refer to communication chapter in inverter manual for different inverter.)

Firstly, controller sends 0 to corresponding register of“STATE(R) ADD” through inverter. After delay for a

while, sends 1 to corresponding register of“RUN1(W) ADD”. After another delay, reads“ RUN S”register, and judges if the inverter is running based on the set formula. Calculate the output frequency based on the comparison of pressure detected and pressure set and send this value to corresponding address of“FREQ(R) ADD” through formula operation.

Schneidel inverter parameter set:

1、CON |AD2-
|AD1-|ADD :1
|EBr :96
|EFO :8N1
|EEO :15
CTL- |Fr1 :ndb
|rln
|PST
|CHCF :IO
|CD1 : ndb
Flt- |PTC-
|rST- |rSF :C107

10 Schematic Diagram

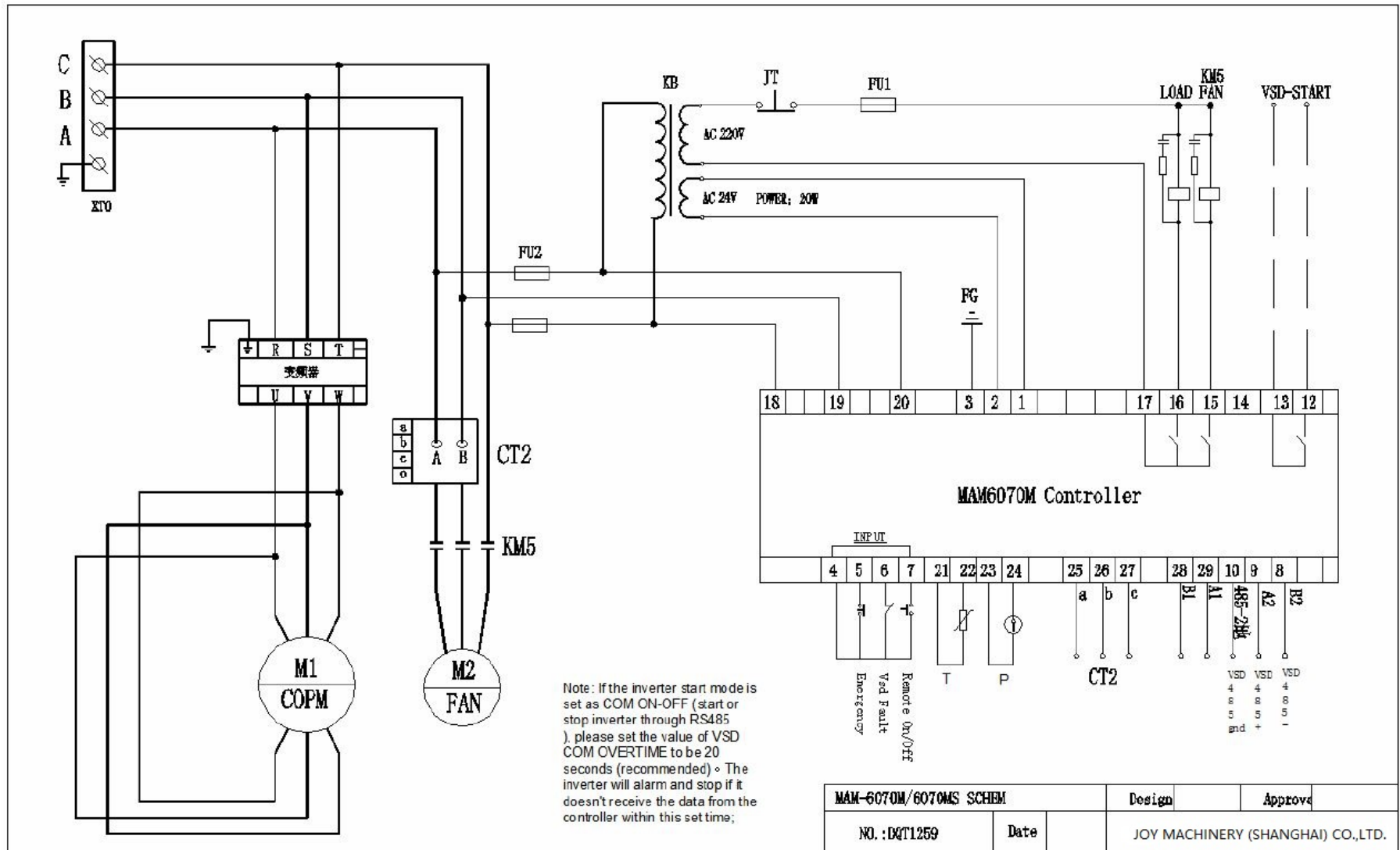

Appendix: Output Mode Introduction:

We add 4 control mode options to controller 6080、6090、6070. User can choose to open or close this function. The introduction is shown as below:

Turn on “output option” in motor VSD parameter, than menu selection interface will increase “output option”. Shown as below:

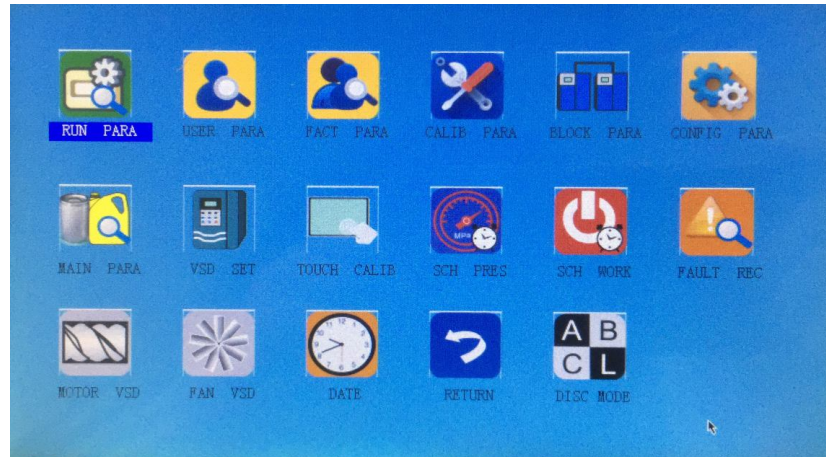

Click “output option” and enter the interface as shown in the below. Users can choose the proper speed adjustment mode according to their needs.

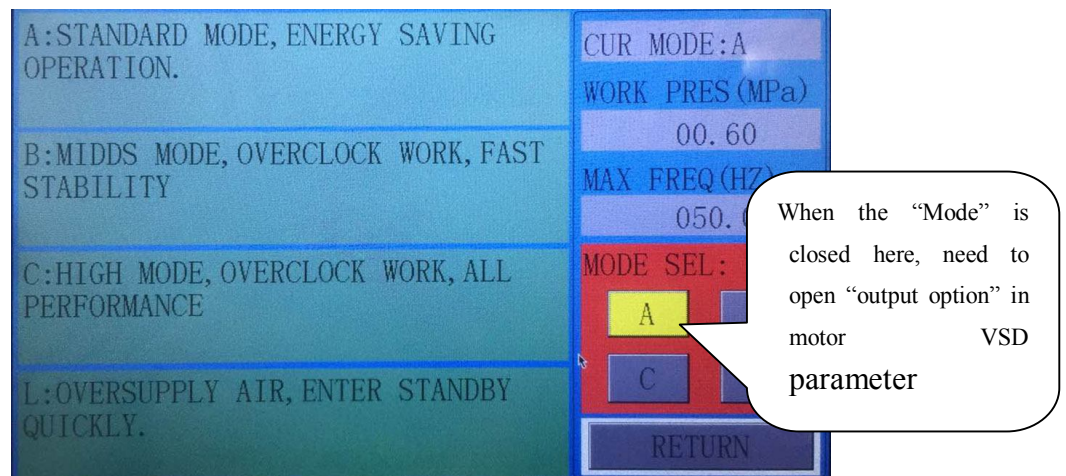

- Mode A: In this mode, the motor is speeded up to motor rated frequency according to inverter maximum acceleration performance after start. After running for some time, pressure is close to constant pressure, then to judge whether brake intelligently according to pressure rise speed, and stabilize pressure to a constant pressure point in one time. (the old version software adopts the model)
- Mode B: (Overclocking operation) In this mode, the motor is speeded up to the corresponding frequency value according to constant power pressure point set by users after start. After running for some time, pressure is close to constant pressure, then to judge whether brake intelligently

according to pressure rise speed, and stabilize pressure to a constant pressure point in one time.

(New mode 1)

- Mode C :(Overclocking and high speed operation). In this mode, the motor is speeded up to the corresponding frequency value according to constant power pressure point set by users after start. Make fastest air output. This mode will take full advantage of the air compressor. (New mode 2)
- Mode L: This mode, based on the mode A, to reduces the running time in low frequency and to achieve the best energy saving effect. (New mode 3)