SCREW AIR COMPRESSOR
TYPE: MAM-KY12S (B) - XII
(LCD DISPLAY-280)

USER
MANUAL

Joy Machinery (Shanghai) Co., Ltd.

Address: Building 8, No.1098, Chuansha Road, Pudong New District
Shanghai City, China

Telephone: (021) 60382839

Website: www.shairbuild.com

Fax: 021) 60382839

E-mail: info@shairbuild.com

VOTE OF THANKS

Thank you for your trustworthy and select of our air compressor controller !

Joy Machinery (Shanghai) Co., Ltd. specializes on the manufacture and R&D of air compressor controller. We are devoted to win customer trust through our high quality products and service.

We try our best to ensure the completeness and correctness of the manual, but our company shall reserve the rights for continuous research and improvement on its products and assume no obligation for the modification and improvement on the previously delivered products. The design of products is subject to the change without notice.

Please feel free to contact our after-sale service center if you encounter any problem with our product.

You are always welcome to make suggestions and advices!

NOTICE



Please read all the operation manual before operating the set and keep this manual for further reference.



Installation of MAM—KY** compressor controller can be performed only by professional technicians.



Installation position shall be considered carefully in order to ensure good ventilation and reduce electromagnetic interference.



Wiring shall be performed respectively according to regulations for heavy and weak current to reduce electromagnetic interference.



RC snubber must be connected to the two terminals of coil (such as AC contactor ,valve, etc),which are controlled by relay output.



Port connection shall be inspected carefully before power on.



Correct ground connection (the third ground)can help increase product capacity of resisting signal interference.



Set rated current of motor: the max current of motor/1.2.

Feature:

- LCD Chinese / English display
- With all-round protection functions of short-circuit, block,open phase, overload and unbalance for motor.
- On-off control of motor.
- Prevention for air compressor reversion.
- Temperature measurement, control and protection.
- Automatic adjusting of rate of load and controlling of pressure balance
- High integration, high reliability, high cost performance
- Remote/Local Mode
- Block control/Single machine/DCS control.
- Function of RS485 communication

CONTENTS

1、 Basic Operation	5
(1).Button Explanation	5
(2). Display of status and operations	6
(3).Customer Parameter (User Parameter) and Functions	8
(4).Manufacturer Parameters	10
2、 Technical parameters and functions	11
3、 Model and Specification	12
(1). Model Description	12
(2). Power consumption Table for Corresponding Motor	12
4、 Installation	12
5、 Alarm Function	15
6、 Controller protection	16
(1) Motor protection	16
(2) Protection of High Discharge Air Temperature	16
(3) Protection of Air Compressor Non-reversing	16
(4) Protection of High Pressure	16
(5) Protection of Sensor Failure	16
7、 Troubleshooting	17
(1). This Fault Review	17
(2). Common Failures and Causes	17
8、 Schematic Diagram	19

1、 Basic Operation

(1).Button Explanation

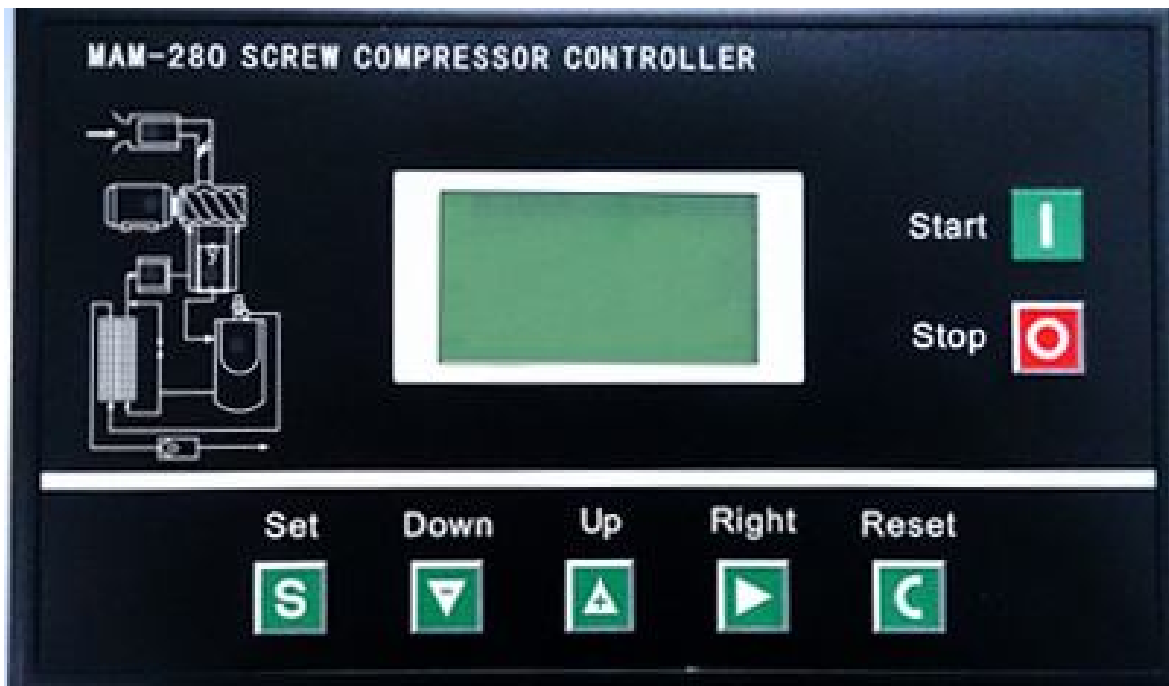

Picture1

| —Start Button:

- 1, When compressor is at stop status, press this button to start the compressor.
- 2, When compressor is set as master (No.1) in block mode, press this button to start the compressor and activate block mode function at the same time.

○ —Stop button:

- 1, When the compressor is at running status, press this button to stop the compressor;
- 2, When compressor is set as master (No.1) in block mode, press this button to stop compressor and block mode function as well;

S — Set Button /Loading / unloading Button:

- 1, When the compressor is at running status, press this button to load, unload;
- 2, When the compressor is at setting mode, press this button after modification to confirm and save the modified data.

▲ —Move up button/Increasing button:

- 1, When viewing the menu, press this button to move upward the cursor;
- 2, When modifying data, press this button to increase the data at current position.

▼ —Move down button / Decreasing button:

- 1, When viewing the menu, press this button to move downward the cursor;
- 2, When modifying data, press this button to decrease the data at current position.

▶—Shift button /Enter button:

- 1, When modifying data, press this button to move to the next data bit;
- 2, When select menu, press this button to switch to submenu. If no submenu available, the controller will shift to data setting mode.

Ⓒ—Return button / Reset button:

- 1, When modifying data, press this button to exist data setting mode;
- 2, When viewing the menu, press this button to return to previous menu;
- 3, When the controller is at failure stop status, long press this button to reset.

(2). Display of status and operations

The display screen will show as below after power on::

WELCOME USING SCREW AIR COMPRESSOR

After 5 seconds, the menu will switch as below:

AIR T: 20°C AIR P: 0.60MPA NORMAL STOP C001 NEAR

Press “▼” to enter into Menu Selection Menu:

:

RUN PARAMETER CUSTOMER SET FACTORY SET

a, Viewing Run Parameter:

Press “▼” or “▲” to move the cursor to “RUN PARAMETER”, press “▶” to switch to submenu:

MOTORS CURRENT TOTAL RUN TIME CURRENT RUN TIME MAINTENANCE SET
--

Press “▶” again to switch to:

MAIN (A)	FAN (A)
R 0.0	0.0
S 0.0	0.0
T 0.0	0.0

If the menu is at the last level, the cursor will disappear. Press the return button “C” to return to the previous menu or the main menu. If the operation stops at a certain menu, it will automatically return to the main menu shortly.

Moving buttons “▼”, “▲”; confirm button “▶” to view other parameters like: Maintenance Parameter, History Failure, Production Time, Current Failure and etc. and to return to the previous menu by button “C”.

b, User Parameter (Customer Parameter):

(1)Parameter Modification

----- User Parameter and Manufacturer Default Parameter can not be modified during running status and stop delay period -----

Please refer to the run parameter to check and modify user Parameter . If you want to modify “LOAD P”, please follow the instructions below:

Press “▼”or “▲”to move the cursor to “Customer Parameter” and then press “▶” to switch to below menu:

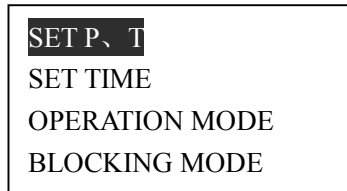

Press “▶” again to switch to :

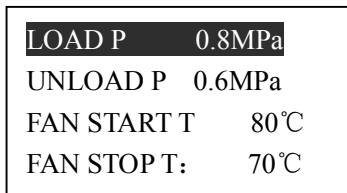

Move the cursor to item LOAD P, then press “▶” to switch to the following menu which requires a user password input.



Attention: User Password can be modified in the “Customer Parameter”; Factory Password is fixed to be

In this menu, the first data bit of password starts blinking, press “▲”or“▼” to modify the first bit of password, Press “▶” to move the cursor to the next data bit, modify the second data of password in accordance with the above , and modify the third and fourth data of password in sequence. Press “S” to confirm the input data and the menu will switch to the following menu after verification:

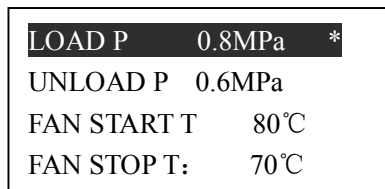

when there is a * displayed at the up right corner which means user can modify the data.

In the menu above , press “▶” , the first data of LOAD P starts blinking ,user can press “▲” or “▼” to modify the present data in accordance with the above method .Press “▶” to move to next data and modify the target data in sequence. When finished, press “S” to confirm and save the data. The controller prompts a short voice to advice the completion of parameter set.

(3).Customer Parameter (User Parameter) and Functions

First Submenu	Second submenu	Preset Value	Functions
SET P. T.	LOAD P.	*.**MPa	1,In AUTO load mode , compressor will load if pressure is below this set data 2,In STANDBY mode, compressor will start if the pressure is below this set data
	UNLOAD P.	*.**Mpa	1,Compressor will unload automatically if air pressure is above this set data 2.This data should be set above LOAD P ,also should be set below UNLND P LIM
	FAN START	***°C	Fan will start if DISC T is above this set data
	FAN STOP	***°C	Fan will stop if DISC T is below this set data
SET TIME	HOST START	0008S	Set the MOTOR START TIME. Record time when motor is activated, controller will not start overload protection during this time to avoid impulse starting current stopping the motor.
	FAN START	0006S	Set the FAN START TIME. Record time when fan is activated, controller will not start overload protection during this time to avoid impulse starting current stopping the fan.
	STAR DELAY	0006S	Interval time from star start to delta start.
	LOAD DELAY	0002S	Unloading in this set time after enter delta running
	EMPTY DELAY	0020M	When unloading continuously, compressor will automatically stop and enter to standby status if over this set time
	STOP DELAY	0010S	For NORMAL STOP operation, compressor will stop after it continuously unloads over this set time
	START DELAY TIME	0100S	Machine can start only over this set time at any case(after normal stop, standby or alarm &stop)
	SPARE TIME	0000S	Additional functions
	DRAIN OPEN	0002S	Auto drain control, continuously drain time
	DRAIN CLOSE	0010M	Auto drain control, continuously drain interval time

OPERATION MODE	ON/OFF MODE	Machine side	When the remote mode is set, both the button beside the machine and the remote control button can turn on and off the machines
	LOAD MODE	Auto	When the manual mode is set, the Load/Unload function can only be executed by pressing buttons
	COM MODE	Prohibited	When this is set as "PROHIBIT" the communication function is not available
	COM ADD	0255	Communication address
BLOCKING MODE	BLK STATE	MASTER / SLAVE	1.When service as master in BLOCK, master controls slave; the COM ADD should be set as No.1 2.When service as slave in BLOCK, slave is controlled by master
	BLK ON/OFF	ORDER	Standby
	TURN TIME	9999 Hours	When master pressure is between BLOCK LOAD P and BLOCK UNLD P, master determines slave to work alternatively after working over this set time
	BLK NUMER	0016	Number of air compressors in block net
	BLK MIN	*.**MPa	In BLOCK mode, one compressor will start or load when master AIR P is below this set data
	BLK MAX	*.**MPa	In BLOCK mode, one compressor will stop or unload when master AIR P is above this set data
	BLK DELAY	0000S	In BLOCK mode, when master sends two commands continuously, second command signal delays for this set data
CLR LIFE TIME	OIL FILTER	0000 HOURS	Record total running time of oil filter. If changing new oil filter, the data should be reset by manual operation.
	O/A FILTER	0000	Record total running time of O/A separator. If changing new O/A separator, the data should be reset by manual operation
	AIR FILTER	0000	Record total running time of air filter .If changing new air filter, the data should be reset by manual operation
	LUBE	0000	Record total running time of lubricant. If changing new lubricant, the data should be reset by manual operation
	GREASE	0000	Record total running time of grease. If changing new grease, the data should be reset by manual operation

MAX LIFE TIME	OIL FILTER	9999s	1, Alarm prompt when total running time of oil filter is above the set data . 2,Set this data to “0000” , alarm function for oil filter running time is not activated
	O/A SEPARATOR	9999s	1, Alarm prompt when total running time of O/A separator is above the set data. 2,Set this data to “0000” ,alarm function for O/A separator running time is not activated
	AIR FILTER	9999	1, Alarm prompt when total running time of air filter is above the set data. 2,Set this data to “0000” , alarm function for air filter running time is not activated
	LUB	9999	1, Alarm prompt when total running time of lubricant is above the set data. 2, Set this data to “0000”, alarm function for lubricant running time is not activated.
	GREASE	9999	1, Alarm prompt when total running time of grease is above the set data. 2,Set this data to “0” , alarm function for grease running time is not activated
LANG.SELECT	EN	CH	Only Chinese Support
NEW USER PIN	****	****	Customer could modify the user password

(4).Manufacturer Parameters

Manufacturer parameter password is required to revise manufacturer parameter .Refer the modification method of user parameter. Table for main functions and purposes is followed

PARAMETER	Initial Value	Functions
HOST CUR	MAXIMUM OVERLOAD VAULE OF THE MOTOR /1.2	After the starting delay time, when the motor current is greater than 1.2 times of the set value and less than 4 times of the set value, the unit will jump as per overload feature.
FAN CUR	Maximum allowable motor overload value/1.2	Same as above
ALARM T.	105℃	Pre-alarm when the temperature reaches this set value
STOP T.	110℃	Alarm when the air exhausting temperature reaches this set value.
STOP P.	1.00MPa	Alarm and stop the machine when the air supply temperature reaches this set value
ULD MAX	0.80MPa	The Unload Limit Pressure in the Customer Parameter must be set lower than this value.
MOD LOAD	****Hours	The manufacturer can modify the load running time
MOD RUN	****Hours	The manufacturer can modify the total running time
RST FAULT	****	Input the history failure password to clear all the history failures.
CUR UN.BAL.	0006	When (the max. phase current / min. phase current) is

		not greater than (1+set value), the unbalance protection will stop the machine. If the set value is greater than 15, the unbalance protection will be unavailable.
LACK PAHSE	005.0	If set time of phase failure ≥ 20 seconds, phase failure doesn't function; If unbalance protection is activated, it will stop operation.
POWER FREQ	50H	Set the power frequency
PROD	****Y**M**D	The manufacturer input the product date of the unit.
PROD NO.	*****	The manufacturer input the product No. of the unit

2、 Technical parameters and functions

- (1). Digital input&output: 8 points of digital input ;10 points of digital relay output ;
- (2). Analog input: 2 point of Pt100 temperature input ; 2 point of 4~20mA pressure signal input; two groups of three phases current inputs(CT provided);
- (3). Input voltage of phase: three phase 380V/220V;
- (4).Controller power supply: AC16-28V、 50/60HZ、 0.3A、 6VA (Recommend:12VA);
- (5).Measurement:

- ①、 Oil temperature:-20~150℃; Accuracy: $\pm 1^\circ\text{C}$.
- ②、 Discharge air:-20~150℃; Accuracy: $\pm 1^\circ\text{C}$.
- ③、 Operation time: 0~999999 hours.
- ④、 Current:0~999.9A.
- ⑤、 Pressure: 0~1.60MPa. Accuracy: 0.01Mpa.

- (6). Phase sequence protection: When compressor is at stop mode and detects wrong phase sequence, respond time $\leq 1\text{s}$ (optional); ;
- (7). Motor protection: This controller has the following basic protection function for main motor and fan. motor

- ①、 Block protection: After start, When operation current is equal to 4 ~8 times the set current ,respond time $\leq 0.2\text{s}$;
- ②、 short circuit protection: When operation current is equal to 8 times the set current, respond time $\leq 0.2\text{s}$;
- ③、 Open phase protection: When any phase opens, the respond time equals to set time, when phase open time is set above 20s,open phase protection is invalid;
- ④、 Unbalance protection: when $\text{MAX-MIN} \geq \text{SET}*\text{MIN}/10$,respond time is 5s;
- ⑤、 Protection features of overload (time unit: second), please see following table (table 2.1.1), multiple

$=I_{\text{actual}} / I_{\text{set}}$,motor operates with delay time according to overload multiples and operation time shown in following table (table 2.1.1) when motor working current is higher or equal to the set current from 1.2 times and 3.0 times .

$I_{\text{actual}}/I_{\text{set}}$	≥ 1.2	≥ 1.3	≥ 1.5	≥ 1.6	≥ 2.0	≥ 3.0
Time parameters						
Operation time (S)	60	48	24	8	5	1

Table 2.1.1 curve table for protection of motor

- (8).Temperature protection: when actual temperature measured is higher than temperature set; response time $\leq 2\text{s}$;

- (9). Contact capacity of output relay: 250V,5A; Contact endurance : 500000 times
- (10). Current error is less than 1.0%.;
- (11). RS485 communication

3、 Model and Specification

(1). Model Description

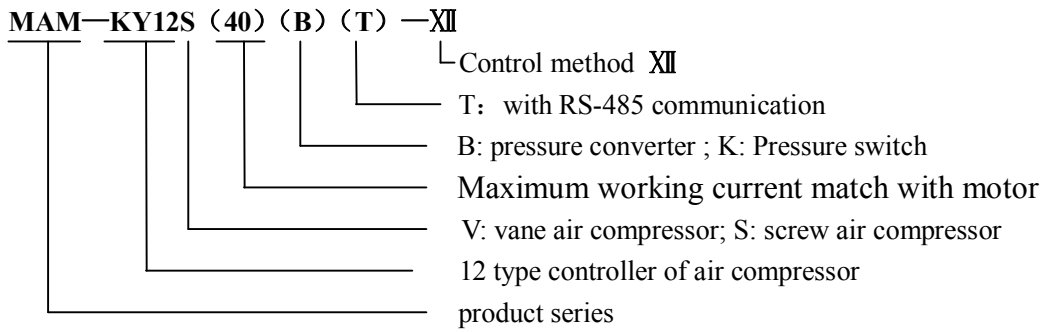

(2). Power consumption Table for Corresponding Motor

Parameter Specification	Current range (A)	Suited main motor power (KW)	Remark	Description
MAM—KY12S (20)	8~20	Below 11		Fan has three levels of current, such as 0.2-2.5A, 1-5A and 4-10A, determined by current of motor
MAM—KY12S (40)	16~40	11-18.5		
MAM—KY12S (100)	100	22-45		
MAM—KY12S (200)	200	55-90		
MAM—KY12S (400)	400	110		
MAM—KY12S (600/5)	600/5	200-250	With CT	

4、 Installation

(1). Current transformer installation

The CT shall be installed at a place where the current of motor cable can be measured, thus controller can be set according to instructions on motor nameplate, the detailed dimensions is shown as below:

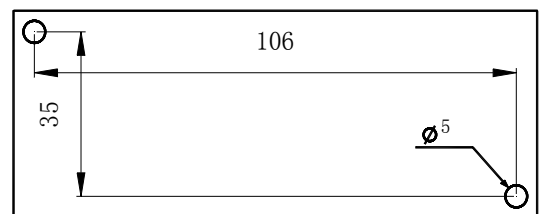
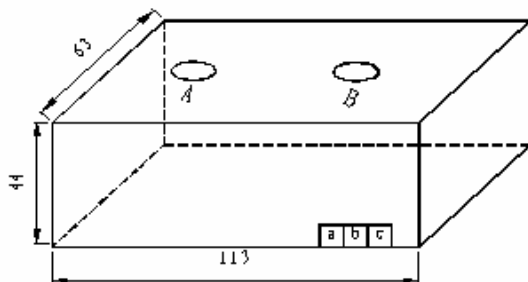

Figure 4.1.1. Structure dimensions of CT1 ($\phi 36$ through hole)

Figure 4.1.2. Installation dimension of CT 1

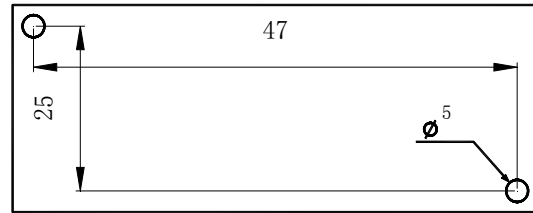
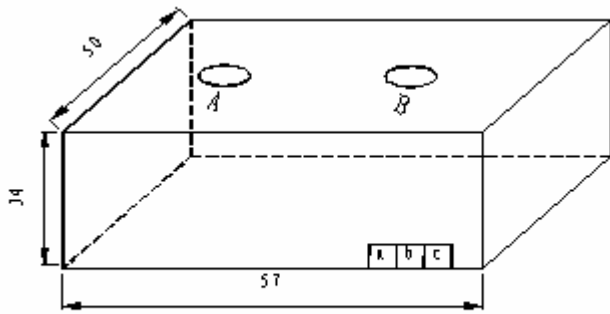
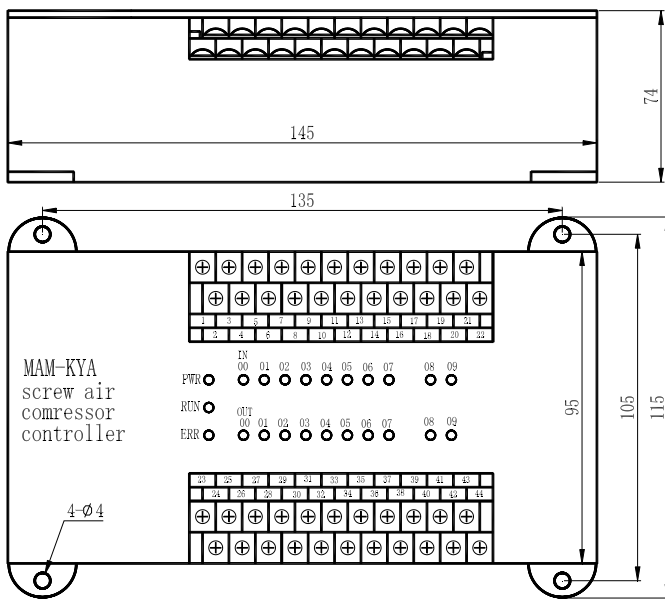

Figure 4.1.3. Structure dimensions of CT2 ($\phi 10$ through hole) Figure 4.1.4. Installation dimensions of CT2
(2). Controller installation

A certain room should be left around controller for wiring. The specific dimension is shown as below



1. Indicator (IN):
The corresponding digital input terminal of 00. 01. 02. 03. 04. 05. 06. 07. is 19. 18. 17. 16. 15. 14. 13.
2. Indicator (OUT)
The corresponding digital input terminal of 00. 01. 02. 03. 04. 05. 06. 07. 08. 09 is 27. 28. 29. 30. 31. 35. 36. 37. 38. 39
3. Power Indicator: PWR
4. Run indicator: RUN
5. Error indicator: ERR

Figure 4.2.1. Controller structure dimension

(3). Functions and installation of display panel

Panel Function and Installation Panel Structure 165×102×50 (mm)。

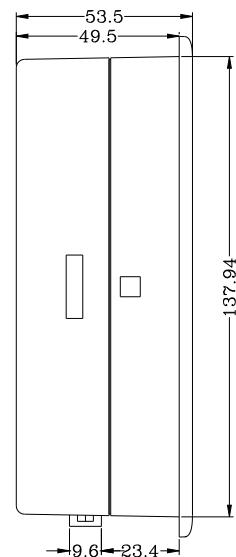
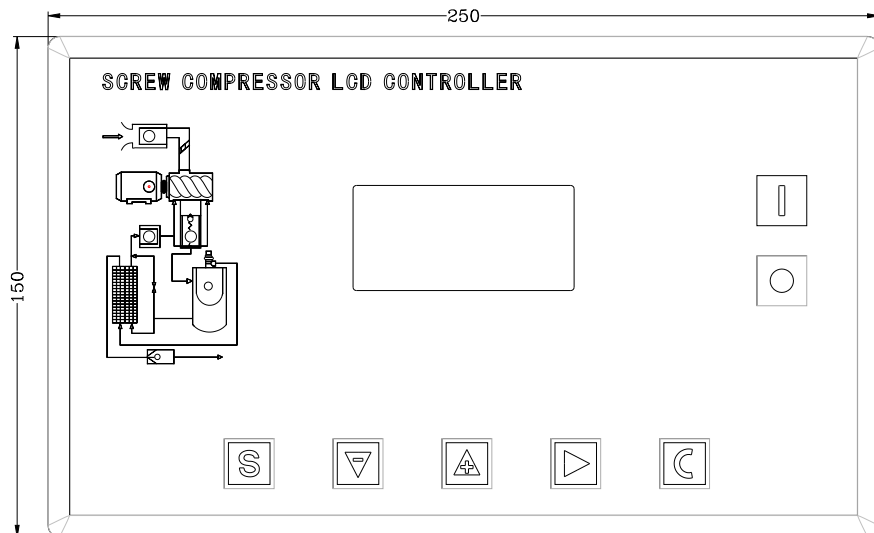

Figure 4.3.1 Panel Dimension

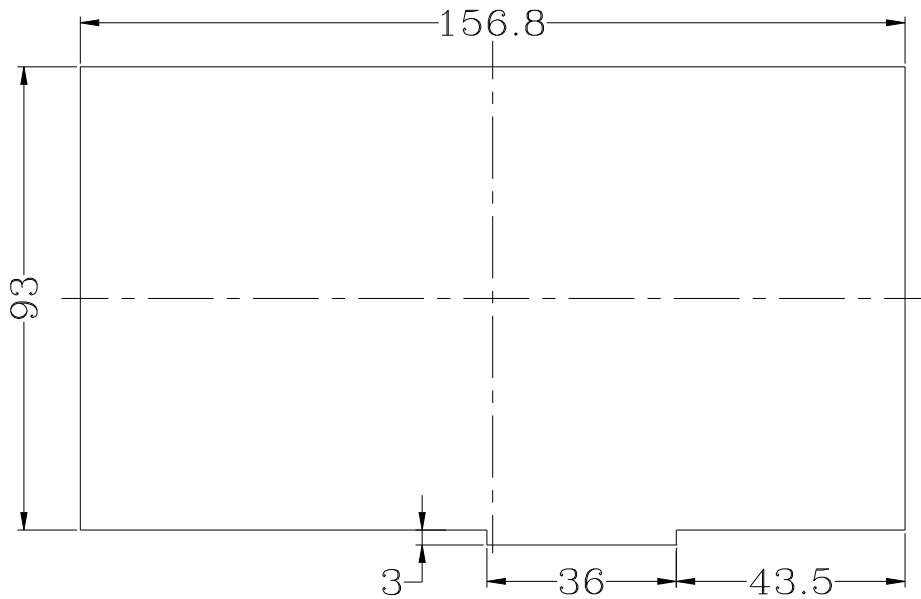

Figure 4.3.2. Hole dimension

(4). Electrical Connections

- ①. Wiring diagram and electrical installation of MAMKY02S are shown in following figure (figure 4.4.1):

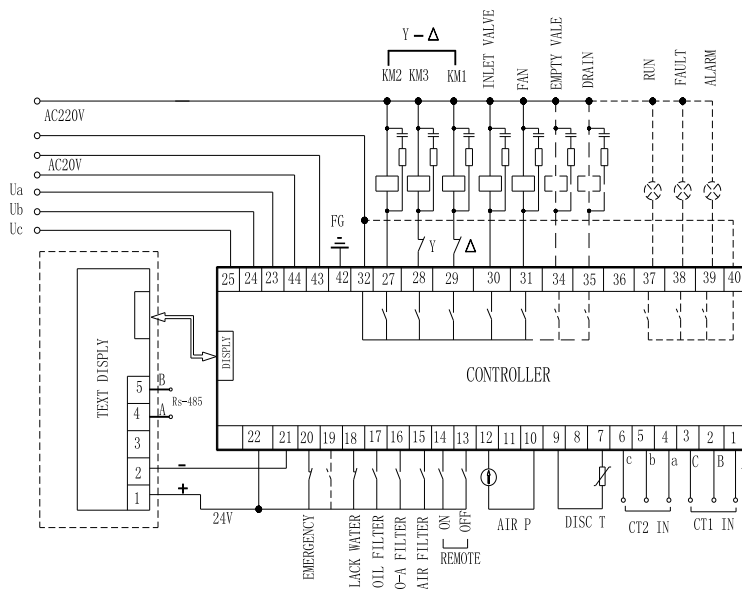

Figure 4.4.1. Terminal arrangement diagram

- ②. Monitor connection cable:

There are five connection cable and a communication cable which are used for display connection ,RS-485 communication ,24V power supply. For detail , please refer to the silk print in monitor

③. Controller cable terminal:

1,2,3	Motor current transformer	4,5,6	Fan current transformer	7. 9	input terminals for discharge temperature
23,24,25	input terminals of phase sequence	27	Main contactor	28	Star contactor
29	Delta contactor	30	Outlet valve	31	Control fan
34	Outlet valve	37	Run indicator	38	Error indicator
39	Alarm indicator	40	COM2	42	Analogue GND
43,44	Power AC20V				

Note : Electromagnetism coil shall be connected nearest with RC snubber during wiring

5、 Alarm Function

(1). Alarm prompts on display

1, Air Filter Alarm

①. Air filter block check.

The monitor displays AIR BLOCK by checking pressure differential switch operating state.

②. Air filter alarm

The text displays AIR LIFE END when running time of the air filter exhausts.

2, Oil Filter Alarm

①. Oil filter block check.

The monitor displays OIL BLOCK by checking pressure differential switch operating state.

②. Oil filter alarm

The text displays OIL LIFE END when running time of the oil filter exhausts.

3, O/A separator Alarm

①. O/A separator block check.

The monitor displays O/A BLOCK by checking pressure differential switch operating state.

②. Oil filter alarm

The text displays O/A LIFE END when running time of the O/A separator exhausts.

4、 Lubricating Oil Alarm

The text displays LUBE LIFE END when running time of the lubricating exhausts.

5, Grease Alarm

The text displays GREASE LIFE END when running time of the grease exhausts.

(2). Prompts on main controller

Indicating item	Meanings and functions	Status of indicator lamp
Power	Energize controller	PWR indicator illuminated

Run	controller operates	RUN indicator illuminated
Error	Shut down when failure is detected	ERR indicator illuminated
Digital input	One of digital input terminals 20-12 is activated	IN00-08 corresponding indicator on, when input terminal is not activated, the indicator
Digital output	One of digital input terminals 27. 28. 29. 30. 31. 35. 36. 37. 38. 39 is	OUT00-09 corresponding indicator illuminated
Data storage	Setting data and storing time	PWR blink once

6、 Controller protection

(1) Motor protection

MAM—KY12S compressor controller provide short circuit ,block, overload, lack phase, unbalance protection to motor.

Electronic failure	Failure display	Reason
Short circuit	Display “MOTOR /FAN OVERLOAD”	Short circuit or wrong current set
Current Block	Display “MOTOR /FAN BLOCK”	Overload, bearing wear and other mechanical failure
Overload	Display “MOTOR /FAN OVERLOAD”	Overload, bearing wear and other mechanical failure
Lack phase	Display “MOTOR /FAN *LACK PHASE”	Power supply, contactor and open phase of motor
Unbalance	Display “MOTOR /FAN UNBALANCE”	Poor contact of contactor, inside open-loop of motor

(2) Protection of High Discharge Air Temperature

When discharge air temperature is above the high limit of set temperature, the controller will send out the alarm to shut down the machine and This fault displays HIGHT T.

(3) Protection of Air Compressor Non-reversing

When compressor stops and three phases sequence is not in order, THIS FAULT displays PHASE REVERSAL, and the controller cannot start the motor. Change the position of any arbitrary two-phase power lines and check the rotation of motor.

(4) Protection of High Pressure

When the discharge air pressure is above the MAX LIM P, the controller will send out the alarm to shut down the machine and THIS FAULT displays HIGH P.

(5) Protection of Sensor Failure

When pressure sensor or temperature sensor is disconnected, the controller will send out the alarm to shut

down the machine and THIS FAULT displays **SENSOR FAULT.

7、 Troubleshooting

(1). This Fault Review

Failure stop caused by the external parts of controllers may be removed by checking THIS FAULT or HISTORY FAULT , method is shown as below:

Press“▼” or “▲”to move the cursor to RUN PARA menu, then press “▶”the secondary menu would be prompted out:

<p>MOTORS CURRENT TOTAL RUN TIME THIS RUN TIME MAINTENANCE SET</p>

Press Down key “▼”:

<p>HISTORY FAULT PROD DATE NO. THIS FAULT</p>
--

Press Enter key “▶” to switch to the following error menu:

<p>STOP:T1 SENSOR FAULT 0170°C</p>
--

User can reset the error according to the following information

(2). Common Failures and Causes

Failure	Reason	Disposal method
High temperature of discharge air	Bad vent condition, Oil shortage etc.	Check the vent condition and lubricant amount etc.
Temperature Sensor Failure	Cable off or PT100 failure	Check the wiring and PT100
High Pressure	Pressure too high or the pressure sensor failure	Check the pressure and the pressure converter
Pressure Sensor Failure	Cable off, Sensor failure or the cable connect reversed	Check the wiring and pressure converter
Lack Water	Water Pressure switch damaged	Check the water pressure switch

Open Phase	Power open phase or the contactor terminal failure	Check the power and contactors
Overload	Voltage too low, tubes block, bearing wear off or other mechanical failure or wrong set data etc.	Check the set data, voltage, bearings, tubes and other mechanical system.
Unbalance	Power unbalance, contactor failure or the internal open loop of the motor	Check the power, contactor and the motor
Block	Voltage too low, tubes blocked, Bearing Wear off or other mechanical failure or wrong set data etc.	Check the set data, Voltage, bearings, tubes and other mechanical system.
Short Circuit	Wrong Wiring, Incorrect Data setting etc.	Checking the wiring and set the data correctly
Wrong Phase Sequence	Reversed phase sequence or open phase	Check the wiring
Fan stopped	Fan damaged, Contactor damaged, no control output	Check the wiring and control output
Overload during start	Master start time set to less than the star delta delay time	Reset the master start time to be longer than star delta delay + 2 seconds
Main Contactor shakes frequently	The emergency button loose, controller reset by interference	Check the wiring; if the coil of contactor connect with surge absorber or not

8. Schematic Diagram

